

# D50i

Reticle parameters (for minimum magnification)

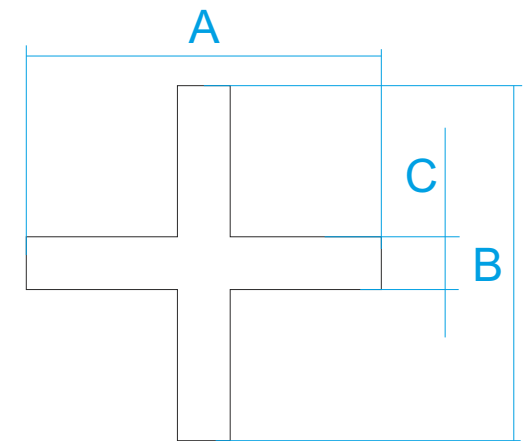

Thermal Imaging Riflescopes  
**THERMION**

Model	MOA					cm @ 100 m				
	XM30	XM38	XM50	XP38	XP50	XM30	XM38	XM50	XP38	XP50
<b>Section A</b>	3.0	2.4	1.8	6.7	5.1	8.8	6.9	5.3	19.6	14.9
<b>Section B</b>	3.0	2.4	1.8	6.7	5.1	8.8	6.9	5.3	19.6	14.9
<b>Section C</b>	0.4	0.3	0.3	1.0	0.7	1.3	1.0	0.8	2.8	2.1

# C50i

Reticle parameters (for minimum magnification)

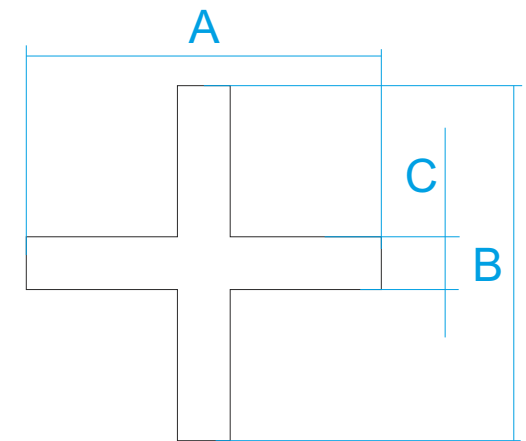
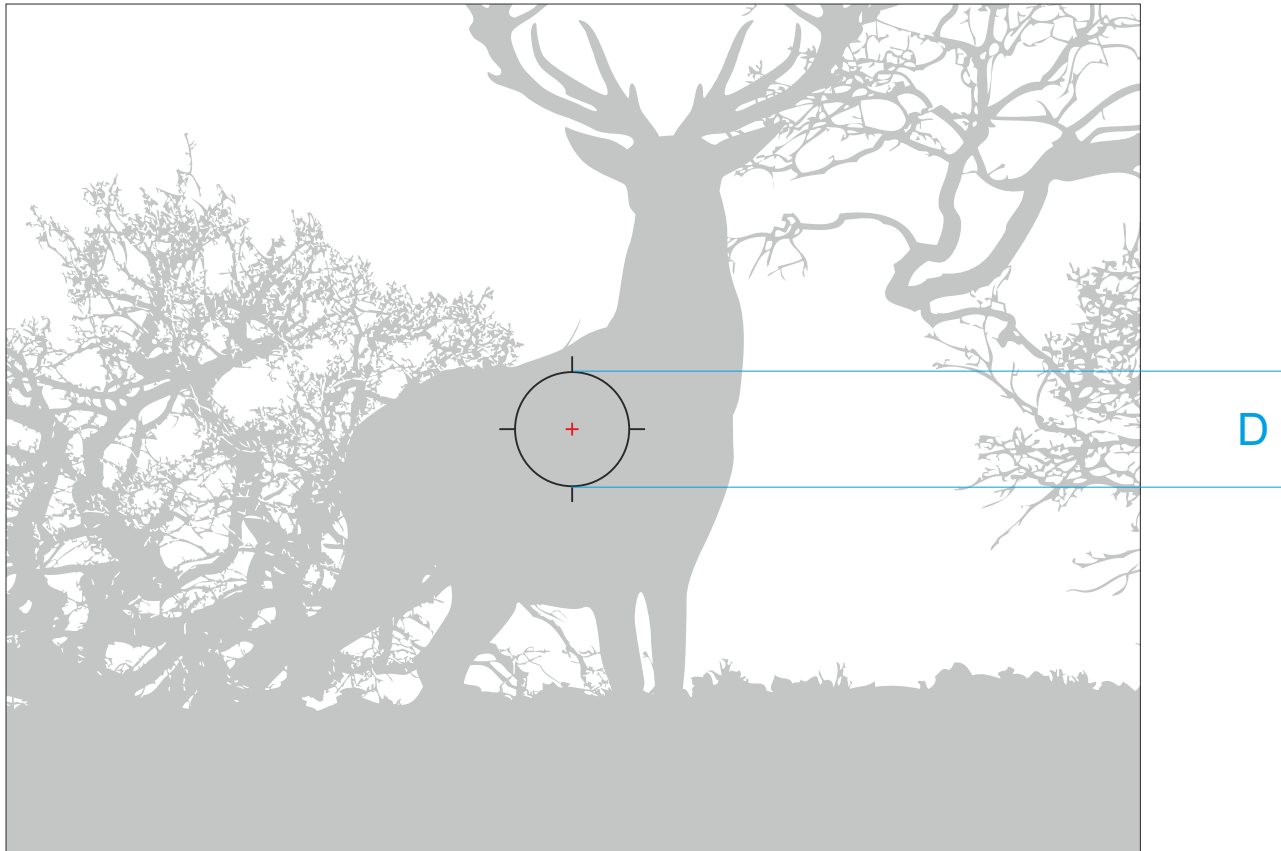

Thermal Imaging Riflescopes  
**THERMION**

Model	MOA					cm @ 100 m				
	XM30	XM38	XM50	XP38	XP50	XM30	XM38	XM50	XP38	XP50
<b>Section A</b>	3.0	2.4	1.8	6.7	5.1	8.8	6.9	5.3	19.6	14.9
<b>Section B</b>	3.0	2.4	1.8	6.7	5.1	8.8	6.9	5.3	19.6	14.9
<b>Section C</b>	0.4	0.3	0.3	1.0	0.7	1.3	1.0	0.8	2.8	2.1
<b>Section D</b>	34.4	34.4	34.4	68.8	68.8	100	100	100	200	200

# X54i

Reticle parameters (for minimum magnification)

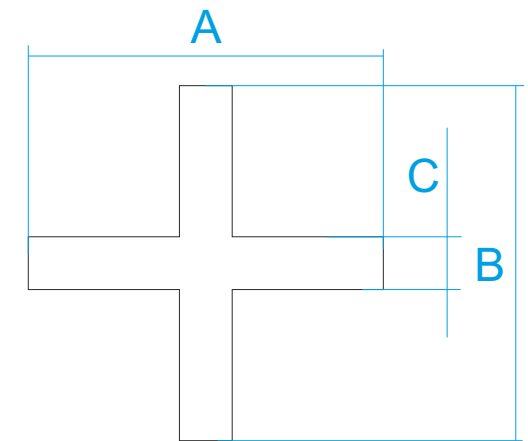
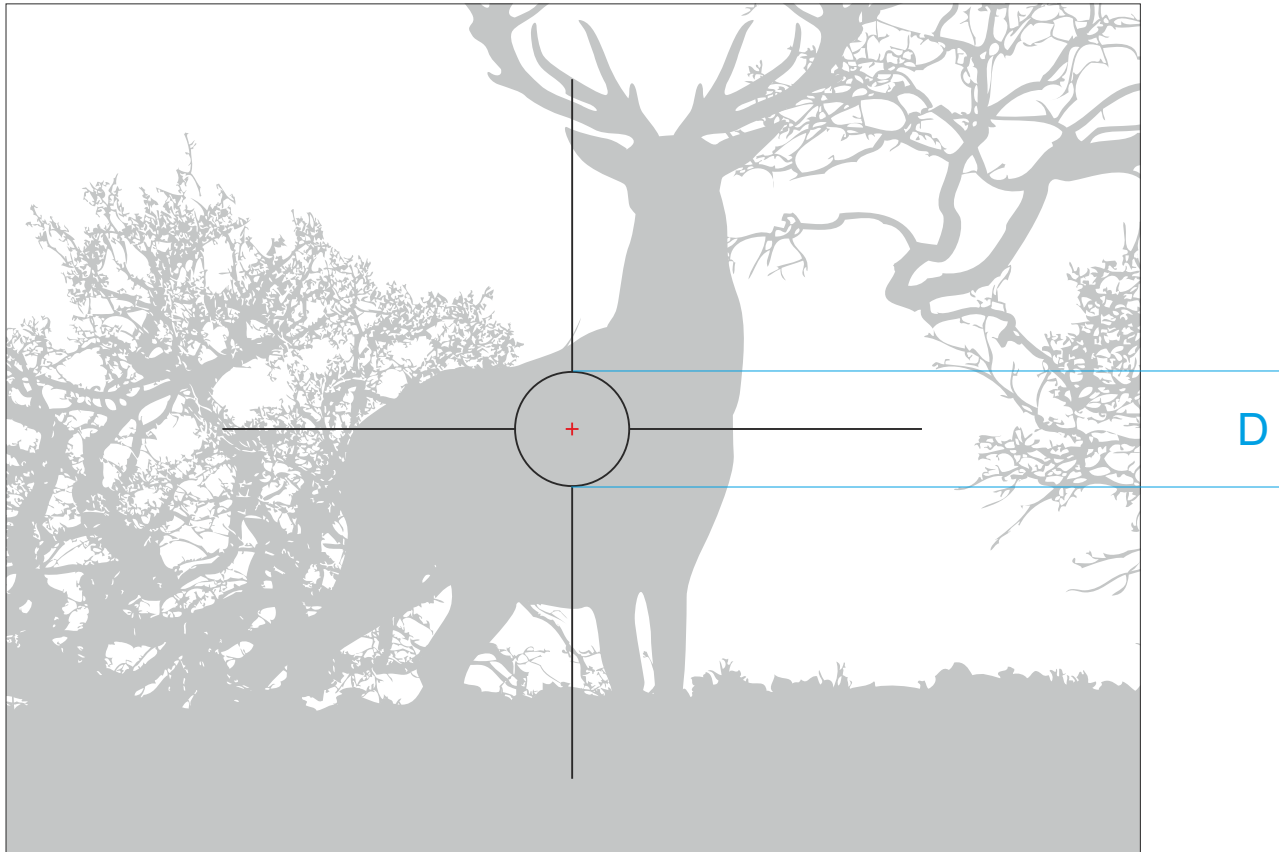

Thermal Imaging Riflescopes  
**THERMION**

Model	MOA					cm @ 100 m				
	XM30	XM38	XM50	XP38	XP50	XM30	XM38	XM50	XP38	XP50
<b>Section A</b>	3.0	2.4	1.8	6.7	5.1	8.8	6.9	5.3	19.6	14.9
<b>Section B</b>	3.0	2.4	1.8	6.7	5.1	8.8	6.9	5.3	19.6	14.9
<b>Section C</b>	0.4	0.3	0.3	1.0	0.7	1.3	1.0	0.8	2.8	2.1
<b>Section D</b>	34.4	34.4	34.4	68.8	68.8	100	100	100	200	200

# H50i

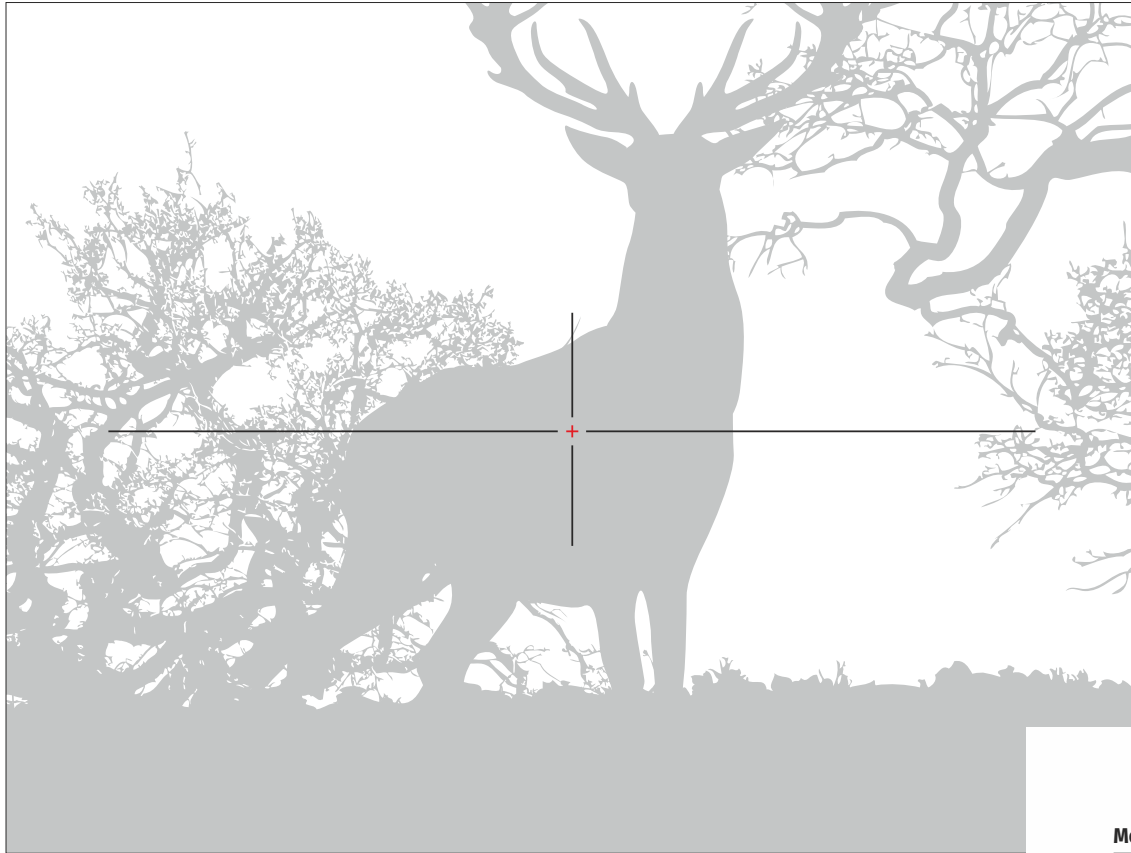

Reticle parameters (for minimum magnification)

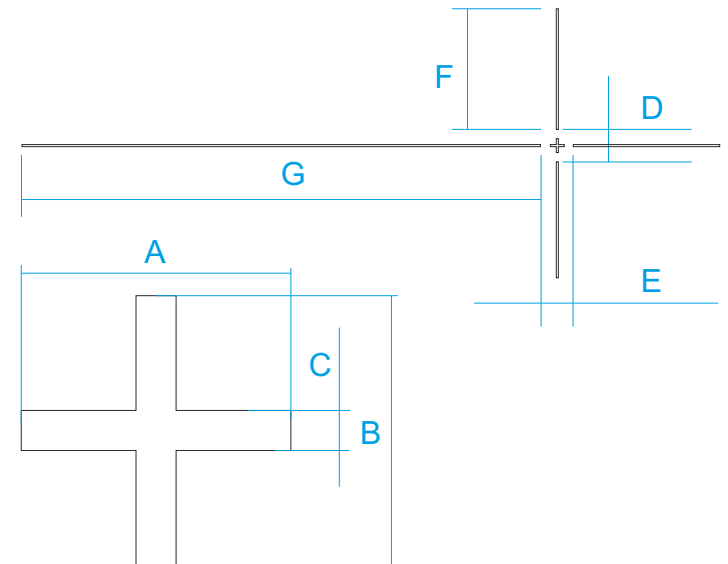

Thermal Imaging Riflescopes  
**THERMION**

Model	MOA					cm @ 100 m				
	XM30	XM38	XM50	XP38	XP50	XM30	XM38	XM50	XP38	XP50
<b>Section A</b>	3.0	2.4	1.8	6.7	5.1	8.8	6.9	5.3	19.6	14.9
<b>Section B</b>	3.0	2.4	1.8	6.7	5.1	8.8	6.9	5.3	19.6	14.9
<b>Section C</b>	0.4	0.3	0.3	1.0	0.7	1.3	1.0	0.8	2.8	2.1
<b>Section D</b>	10	10	10	20	20	29	29	29	58	58
<b>Section E</b>	10	10	10	20	20	29	29	29	58	58
<b>Section F</b>	38.2	29.1	21	86.7	63.5	111	85	61	252	185
<b>Section G</b>	130	102	76	292.4	219.8	379	296	221	851	640

# X50i

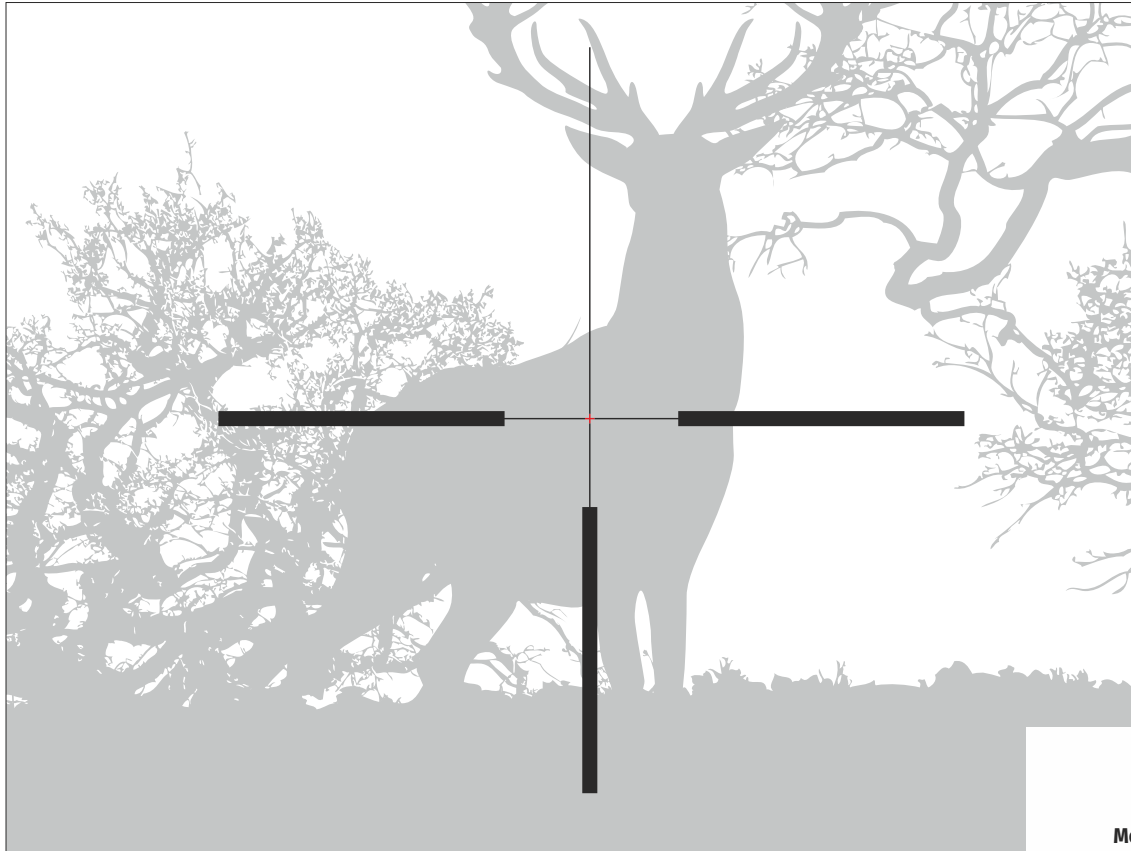

Reticle parameters (for minimum magnification)

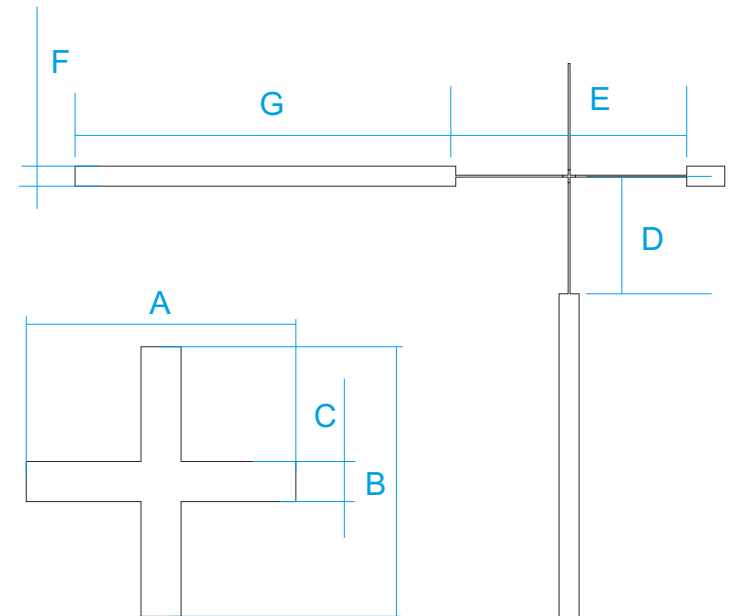

Thermal Imaging Riflescopes  
**THERMION**

Model	MOA					cm @ 100 m				
	XM30	XM38	XM50	XP38	XP50	XM30	XM38	XM50	XP38	XP50
Section A	3.0	2.4	1.8	6.7	5.1	8.8	6.9	5.3	19.6	14.9
Section B	3.0	2.4	1.8	6.7	5.1	8.8	6.9	5.3	19.6	14.9
Section C	0.4	0.3	0.3	1.0	0.7	1.3	1.0	0.8	2.8	2.1
Section D	17.2	17.2	17.2	34.4	34.4	50	50	50	100	100
Section E	34.4	34.4	34.4	68.8	68.8	100	100	100	200	200
Section F	1.2	1	1	3	2.1	3.5	2.9	2.9	8.7	6.1
Section G	118	90	64	267	195	343	260	186	779	568

# T54i

Reticle parameters (for minimum magnification)

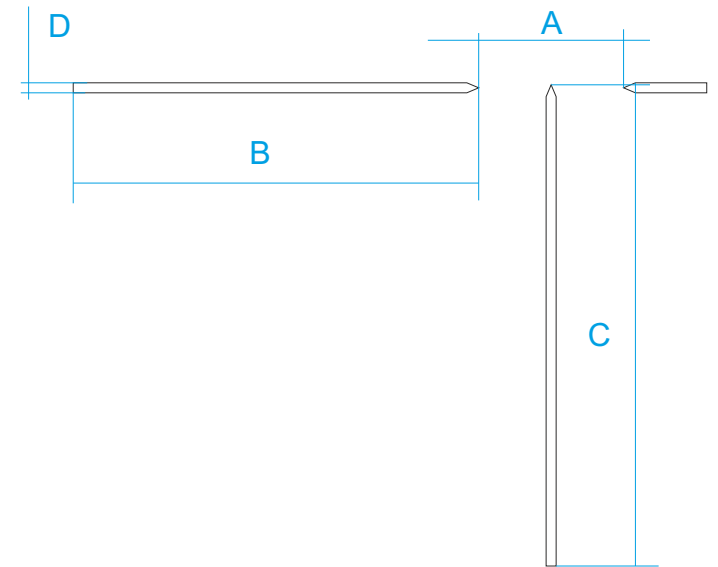

Thermal Imaging Riflescopes  
**THERMION**

Model	MOA					cm @ 100 m				
	XM30	XM38	XM50	XP38	XP50	XM30	XM38	XM50	XP38	XP50
<b>Section A</b>	34.4	34.4	34.4	68.8	68.8	100	100	100	200	200
<b>Section B</b>	118	89	64	268	195	343	260	186	779	567
<b>Section C</b>	137	108	82	306	232	398	314	239	889	676
<b>Section D</b>	3	2.4	1.8	6.7	5.1	8.8	7	5.3	19.6	15

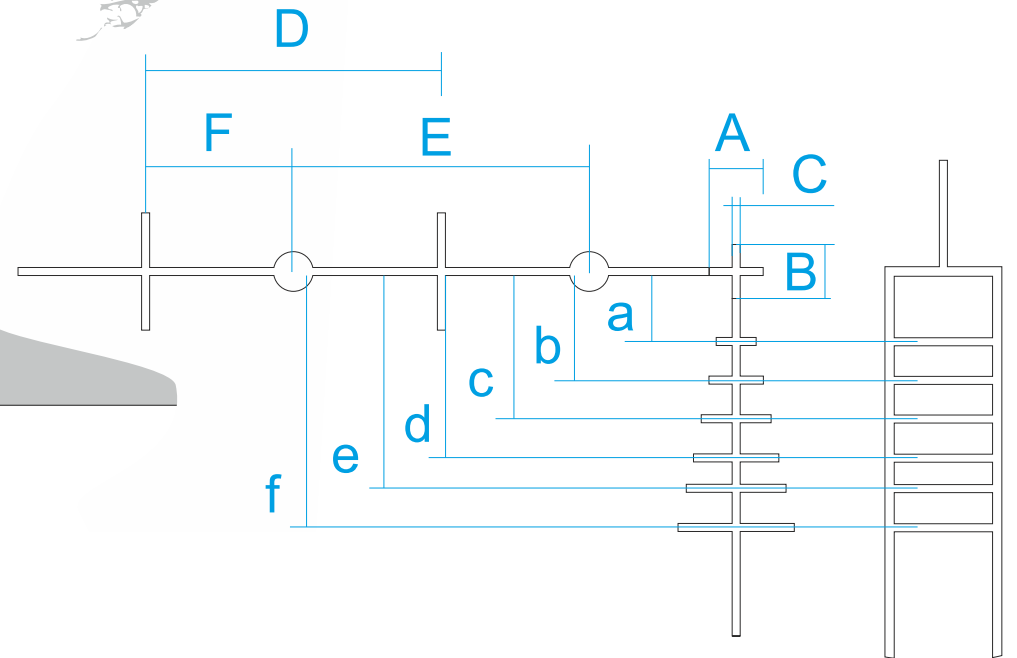
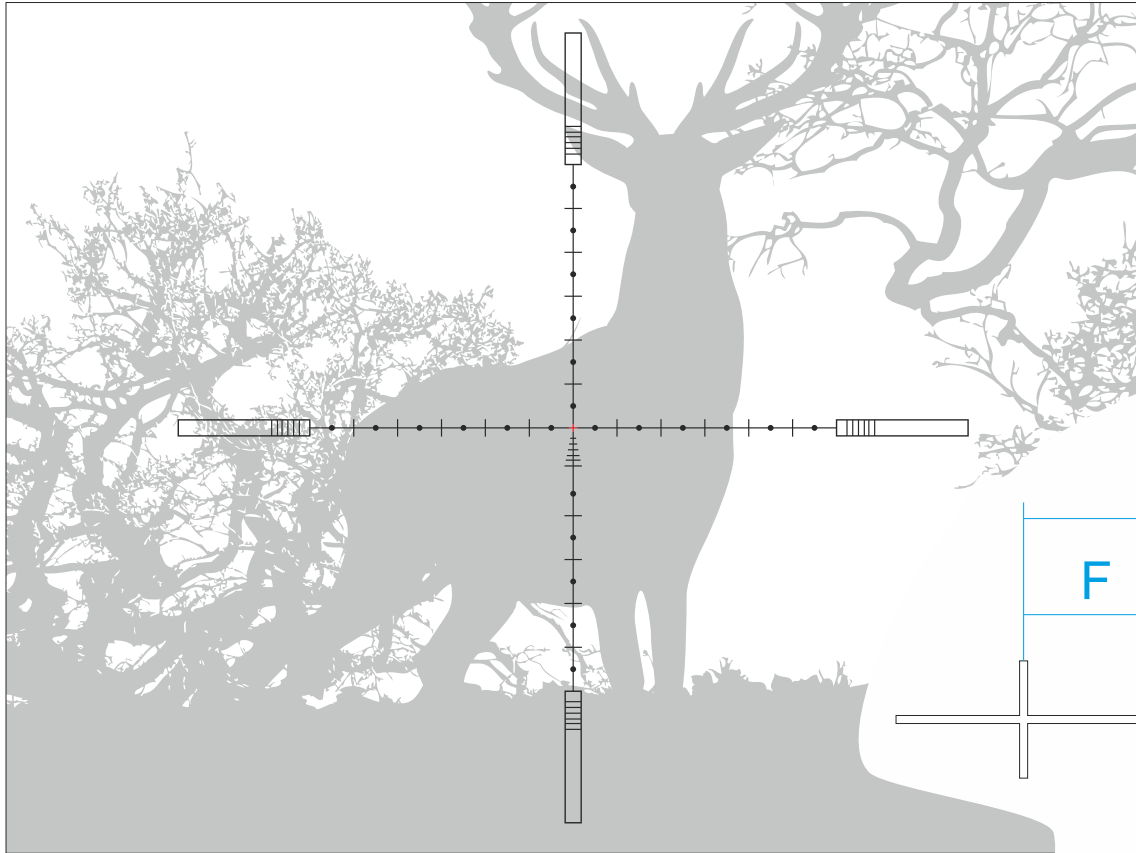

### THERMION XP38

	MOA	cm @ 100 m
<b>Section A</b>	6.7	19.6 On minimal magnification
<b>Section B</b>	6.7	19.6 On minimal magnification
<b>Section C</b>	1	2.9 On minimal magnification
<b>Section D</b>	3.5	10 (1 mil) On 12x magnification
<b>Section E</b>	3.5	10 (1 mil) On 12x magnification
<b>Section F</b>	3.5	10 (1 mil) On 6x magnification

<b>Section a</b>	1 mil (10 cm @ 100 m) on 1.5x magnification
<b>Section b</b>	1 mil (10 cm @ 100 m) on 3x magnification
<b>Section c</b>	1 mil (10 cm @ 100 m) on 6x magnification
<b>Section d</b>	1 mil (10 cm @ 100 m) on 9x magnification
<b>Section e</b>	1 mil (10 cm @ 100 m) on 12x magnification

### THERMION XM30

	MOA	cm @ 100 m
<b>Section A</b>	3.0	8.8 On minimal magnification
<b>Section B</b>	3.0	8.8 On minimal magnification
<b>Section C</b>	0.4	1.3 On minimal magnification
<b>Section D</b>	3.5	10 (1 mil) On 14x magnification
<b>Section E</b>	3.5	10 (1 mil) On 14x magnification
<b>Section F</b>	3.5	10 (1 mil) On 7x magnification

<b>Section a</b>	1 mil (10 cm @ 100 m) on 3.5x magnification
<b>Section b</b>	1 mil (10 cm @ 100 m) on 5x magnification
<b>Section c</b>	1 mil (10 cm @ 100 m) on 7x magnification
<b>Section d</b>	1 mil (10 cm @ 100 m) on 10x magnification
<b>Section e</b>	1 mil (10 cm @ 100 m) on 14x magnification

### THERMION XP50

	MOA	cm @ 100 m
<b>Section A</b>	3.0	14.9 On minimal magnification
<b>Section B</b>	3.0	14.9 On minimal magnification
<b>Section C</b>	0.4	2 On minimal magnification
<b>Section D</b>	3.5	10 (1 mil) On 16x magnification
<b>Section E</b>	3.5	10 (1 mil) On 16x magnification
<b>Section F</b>	3.5	10 (1 mil) On 8x magnification

<b>Section a</b>	1 mil (10 cm @ 100 m) on 2x magnification
<b>Section b</b>	1 mil (10 cm @ 100 m) on 4x magnification
<b>Section c</b>	1 mil (10 cm @ 100 m) on 8x magnification
<b>Section d</b>	1 mil (10 cm @ 100 m) on 12x magnification
<b>Section e</b>	1 mil (10 cm @ 100 m) on 16x magnification

### THERMION XM38

	MOA	cm @ 100 m
<b>Section A</b>	2.4	6.9 On minimal magnification
<b>Section B</b>	2.4	6.9 On minimal magnification
<b>Section C</b>	0.3	1.0 On minimal magnification
<b>Section D</b>	3.5	10 (1 mil) On 16x magnification
<b>Section E</b>	3.5	10 (1 mil) On 16x magnification
<b>Section F</b>	3.5	10 (1 mil) On 8x magnification

<b>Section a</b>	1 mil (10 cm @ 100 m) on 4x magnification
<b>Section b</b>	1 mil (10 cm @ 100 m) on 6x magnification
<b>Section c</b>	1 mil (10 cm @ 100 m) on 8x magnification
<b>Section d</b>	1 mil (10 cm @ 100 m) on 12x magnification
<b>Section e</b>	1 mil (10 cm @ 100 m) on 16x magnification

### THERMION XM50

	MOA	cm @ 100 m
<b>Section A</b>	1.8	5.3 On minimal magnification
<b>Section B</b>	1.8	5.3 On minimal magnification
<b>Section C</b>	0.3	0.8 On minimal magnification
<b>Section D</b>	3.5	10 (1 mil) On 22x magnification
<b>Section E</b>	3.5	10 (1 mil) On 22x magnification
<b>Section F</b>	3.5	10 (1 mil) On 11x magnification

<b>Section a</b>	1 mil (10 cm @ 100 m) on 5.5x magnification
<b>Section b</b>	1 mil (10 cm @ 100 m) on 8x magnification
<b>Section c</b>	1 mil (10 cm @ 100 m) on 11x magnification
<b>Section d</b>	1 mil (10 cm @ 100 m) on 15x magnification
<b>Section e</b>	1 mil (10 cm @ 100 m) on 19x magnification
<b>Section f</b>	1 mil (10 cm @ 100 m) on 22x magnification



**SCALABLE**

# X51Fi-300

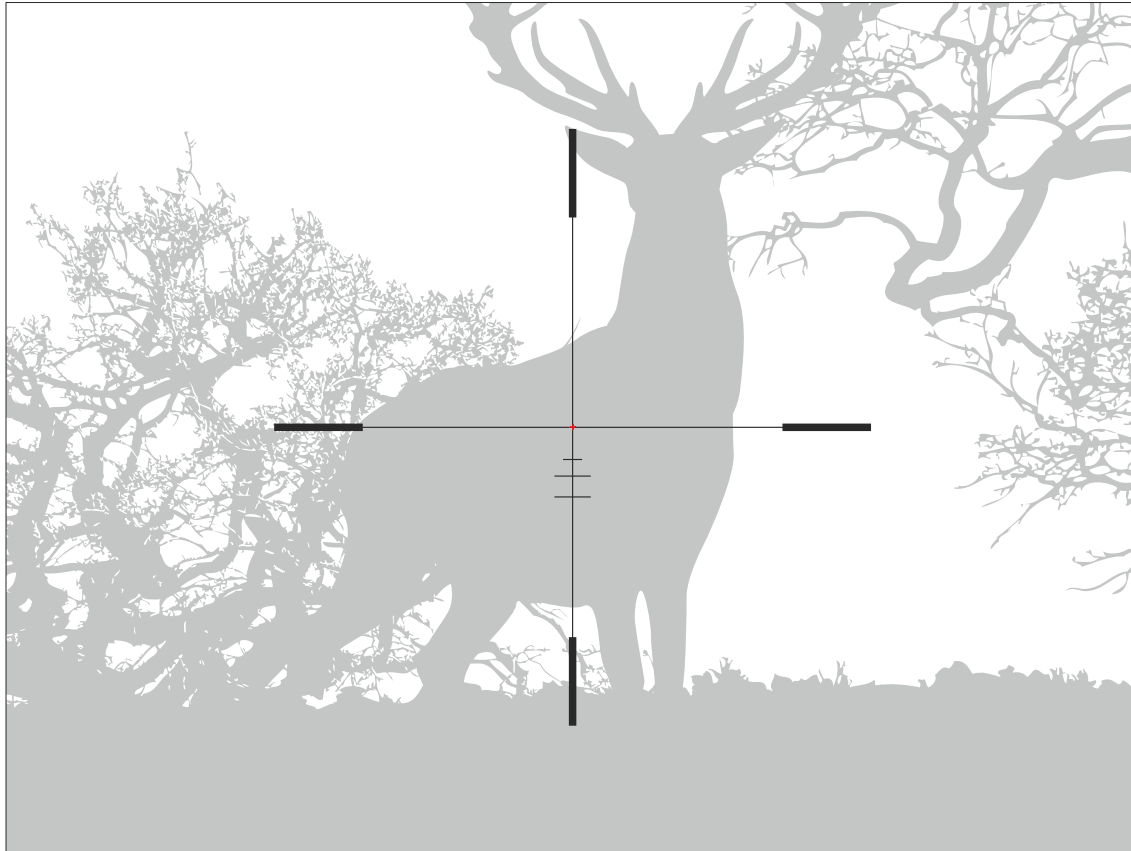

Reticle parameters (apply to all magnifications)

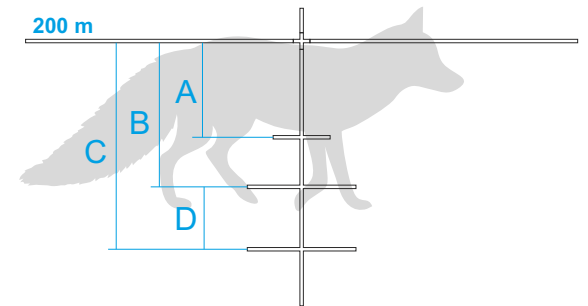

	200 m	300 m
<b>Section A</b>	15 cm (fox body)	23 cm (roe deer body)
<b>Section B</b>	23 cm (roe deer body)	35 cm (wild boar body)
<b>Section C</b>	35 cm (wild boar body)	50 cm (deer body)
<b>Section D</b>	—	15 cm (fox body)

**SCALABLE**

# M56Fi

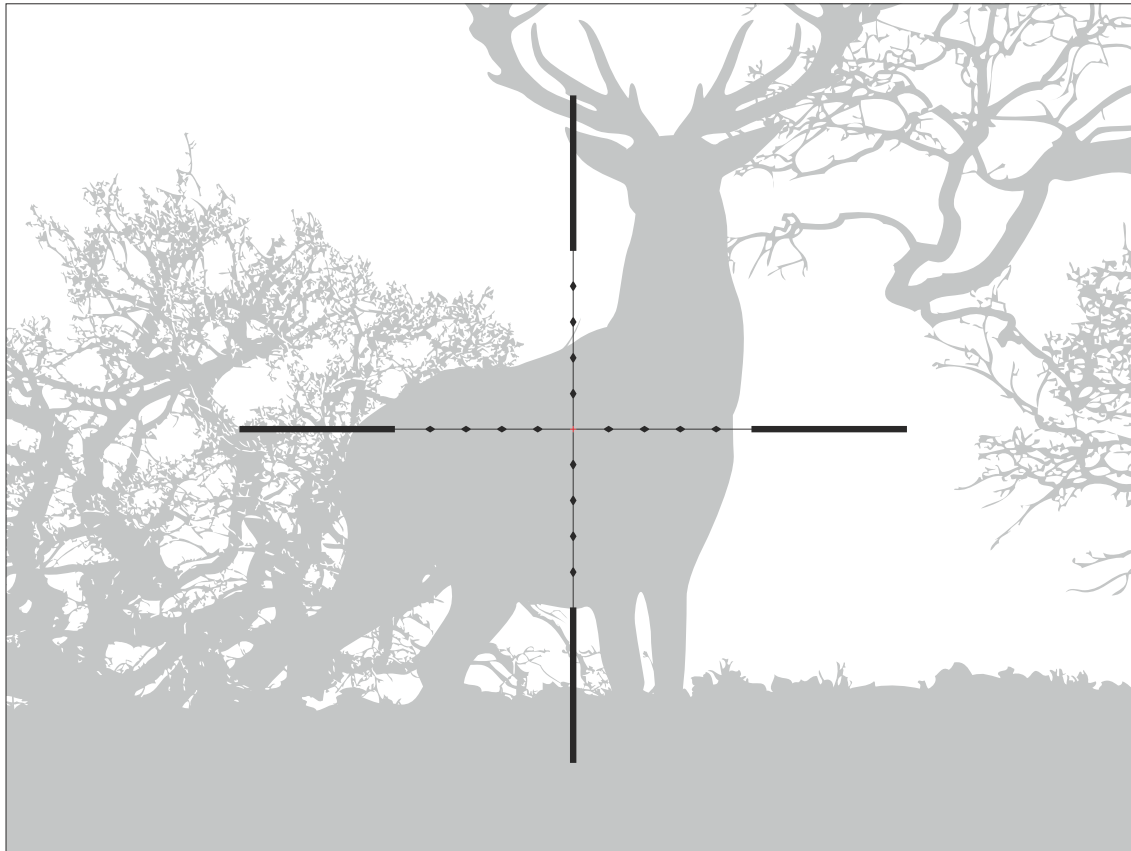

Reticle parameters (apply to all magnifications)

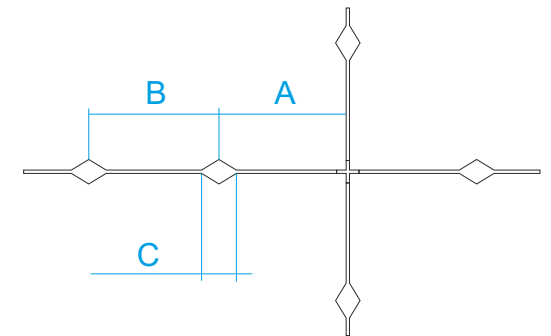

	MOA	cm @ 100 m
<b>Section A</b>	3.5	10 (1 mil)
<b>Section B</b>	3.5	10 (1 mil)
<b>Section C</b>	0.86	2.5 (0.25 mil)

**SCALABLE**

# M57Fi

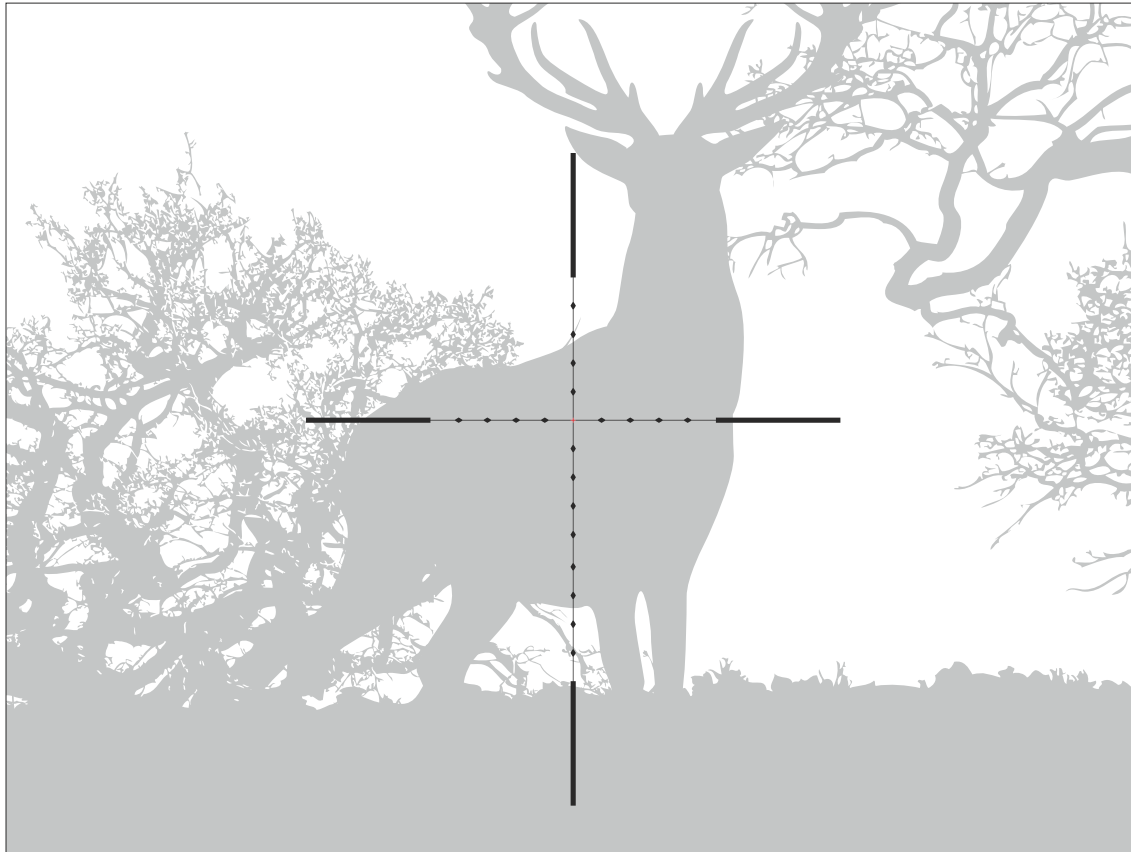

Reticle parameters (apply to all magnifications)

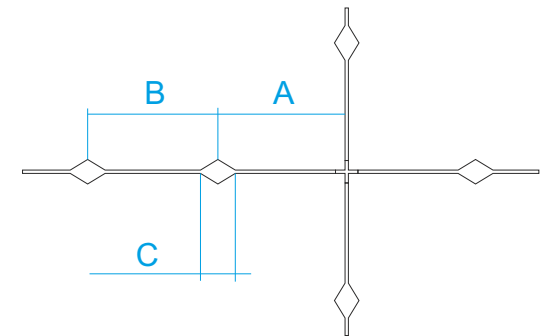

	MOA	cm @ 100 m
<b>Section A</b>	3.5	10 (1 mil)
<b>Section B</b>	3.5	10 (1 mil)
<b>Section C</b>	0.86	2.5 (0.25 mil)