



LEAPERS[®], INC.

OPTICS

USER MANUAL

MAGNIFIER SERIES

**Complete Installation and
Operating Instructions**

WWW.LEAPERS.COM

LEAPERS[®] INC.

Proudly Presents



TOTAL SOLUTION TO YOUR NEEDS

COMMITMENT TO BEST QUALITY, BEST VALUE AND BEST SERVICE

www.LEAPERS.com
32700 Capitol Street
Livonia, MI 48150 U.S.A.
Tel:(734)542-1500
Fax:(734)542-7095
Email:office@leapers.com

Index

A. Specifications	6
B. Major Features	6
C. Mounting the Magnifier	8
D. Switch Between Vertical/Flip-over Positions	12
E. Adjusting Focus / Diopter Setting	12
F. View Centering	13
G. Care and Maintenance	14
H. Lifetime Manufacturer's Warranty	14

UTG NEW GEN 3X MAGNIFIER

MODEL NO.: SCP-MF3WQ

Configuration 1: Low Profile Configuration with Mounting Deck Only

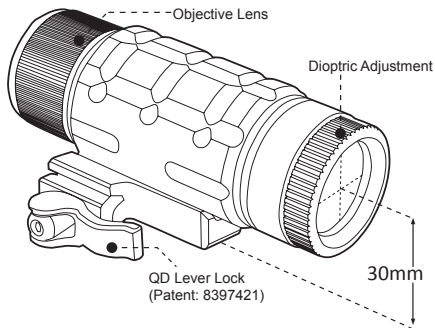

Configuration 2: Medium Profile Configuration with Riser & Mounting Deck

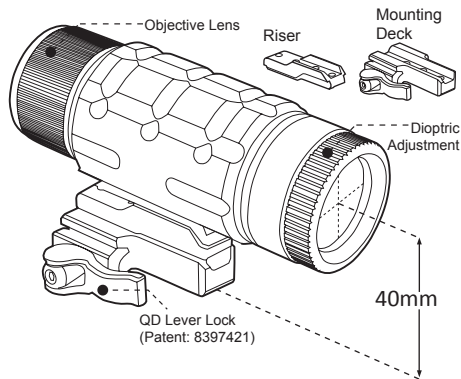

UTG FLIP-TO-SIDE 3X MAGNIFIER

MODEL NO.: SCP-MF3WQS

Medium Profile Configuration with Flip-to-Side QD Mounting Deck

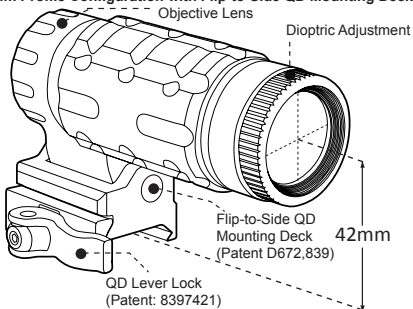

UTG FLIP-TO-SIDE 3X MAGNIFIER WINDAGE/ELEVATION ADJUSTABLE

MODEL NO.: SCP-MF3WEQS

Medium Profile Configuration with Flip-to-Side QD Mounting Deck

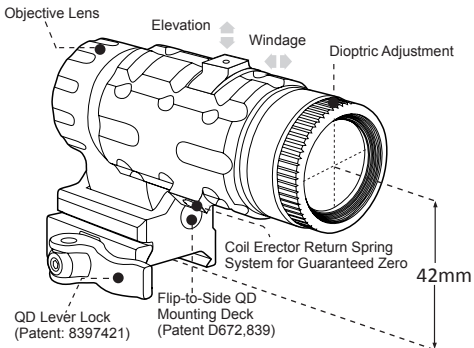

A. Specifications

Magnification	3X
Objective Diameter	25 mm
Field of View	45'
Exit Pupil Diameter	8.7mm
Eye Relief	2"
Center Height	SCP-MF3WQ: 30mm/40mm SCP-MF3WQS: 42mm SCP-MF3WEQS: 42mm
Length	4"
Weight	SCP-MF3WQ: 9.2 oz SCP-MF3WQS: 10 oz SCP-MF3WEQS: 11.8 oz
Lens Coating	Broadband Multi-layer Emerald Coating
Compatible Rail	Picatinny/Weaver

B. Major Features:

- ▶ **Built on True Strength Platform, Shockproof and Fog-proof**
 - Rock solid robust construction, high quality precision parts machined to exact tolerances from aircraft-grade aluminum alloy for maximum strength.
 - Completely sealed and nitrogen filled (may vary on different models) to eliminate risk of water ingress and fogging.
- ▶ **Multi Layer Lens Coating for Optimum Light Transmission**
 - Unique high tech Emerald lens coating applications ensure much superior light transmission and optimize optical performance.

- Multi layer coatings allow for maximum utilization of all ambient light to optimize resolution and clarity.

- ▶ **Adjustable Eyepiece for Easy Dioptic Correction**
- ▶ **Superior Enlarged Field of View Allows for Quick Target Acquisition and Precise Aiming**
- ▶ **3X Magnification and Optic Enhancer for Most Dot Sights**
 - Ideal height for low profile applications close to the bore or medium profile applications for co-witnessing with iron sights.
 - Built-in corrective lens system to turn a glaring dot to the perfect dot when used with a dot sight.
 - Magnified view through a sharp dot sight provides an instant improvement on accuracy without any compromise.
- ▶ **Versatile and Dependable Quick-detach Mounts for a Wide Variety of Applications (SCP-MF3WQ)**
 - Low profile quick detachable mount with adjustable positions for optimal eye relief.
 - A smart riser raises the center height with adjustable positions for further eye relief adjustment.

- ▶ **Innovative and Solid Flip-to-Side Design for Tactical Applications (SCP-MF3WQS/SCP-MF3WEQS)**
 - At vertical position, medium profile to perfectly co-witness with dot sight and AR iron sights, providing 3X magnification for accurate aiming.
 - At flip-over position, clear the view for quick aiming with dot sight only.
 - Easy one-hand switch between two positions, and solid locking in each position with no wobbling under recoil.
- ▶ **Windage/Elevation Adjustable to Maximize Flexibility and Optimize Compatibility with Dot Sight(SCP-MF3WEQS)**

C. Mounting the Magnifier:

CAUTION: Always ensure your rifle is UNLOADED, UNCOCKED and, where applicable, the safety catch is applied before fitting the scope. Practice safe handling procedures at all times.

1. Follow proper installation procedures to install your dot sight on the rifle.
2. SCP-MF3WQ: The magnifier comes with a low profile QD mount and a versatile riser. Use the QD mount only or both mount and riser to achieve an optimal center height to match your dot sight height. When installing the QD mount or both mount and riser, select appropriate part direction and installation holes to attain optimal

eye relief. Refer to Step 5 for QD Mount and Riser Installation Instructions.

3. Hold the magnifier behind the dot sight rifle at your natural shooting position. Locate a proper rail slot position for the magnifier so you can achieve a full field of view and optimal eye relief as shown in Fig 1. It may require adjustment of the dot sight position.



Fig 1.

4. Align and install the magnifier onto the selected Picatinny rail slot. Follow instructions below to adjust for optimal tension for quick detach, locking and unlocking of the magnifier.

- a. Turn the Cam Lever toward its unlocked position as shown in Fig 2.

Place the QD mount on the Picatinny rail at the desired position. Make sure to seat the cross bolt into a selected slot.



Fig 2.

- b. Turn the Cam Lever toward the locking position to begin locking the QD mount on the rail, but do not complete the locking motion, leaving some travel distance to allow for adjustment.
- c. Use the included Allen wrench to adjust the hex screw at the side of the cam for

proper tension and fit against the rail. Adjust clockwise to increase the tension and tighten the clamping width. Adjust counter-clockwise to decrease the tension and increase the clamping width.

- d. The optimal tension is achieved when the side plate first makes contact with the Picatinny rail while the Cam Lever still has enough travel left for you to securely snap into its locking position. Once you achieve the optimal tension, push the Cam Lever all the way for a positive lock onto the rail. You may repeat Step c and d if needed to find the best clamping tension and locking position for your mount.
- e. Now your QD Cam Lever is set for quick detach operations. You may regularly inspect and adjust the tension for best fit.

5. QD Mount and Riser Installation Instructions (SCP-MF3WQ)

- a. Use QD Mount Only: The mount comes with 3 locking holes allowing space adjustment to achieve optimal eye relief. The mount can be used bi-directionally per your preference. Being able to bi-directionally set up the mount maximizes the adjustment range of eye relief. Locate two set screws and install a spring washer onto each screw. Based on your eye relief preference, select two holes out of the 3 on the QD mount and align them with the

mating magnifier holes. Install and fasten the set screws to fully secure the mount as shown in Fig 3.

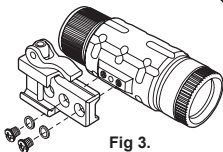

Fig 3.

- b. Use QD Mount and Riser: This configuration offers many different position options with the bi-directional mounting feature available on both the QD mount and the riser. **(Note:** Illustration figure shows only one example direction.) Locate four set screws and install a spring washer onto each screw.

- i. Install Riser: Align the riser to the mating base on the magnifier based on the direction suitable for your application. Install and fasten two set screws to fully secure the riser as shown in

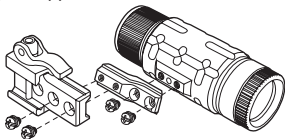

Fig 4.

- ii. Install QD Mount: Based on your eye relief preference, select two holes out of the 3 on the QD mount and align them to the mating holes on the extruded part of the riser. Install and fasten the remaining two set screws to fully secure the mount as shown in Fig 4.

D. Switch Between Vertical/Flip-over Positions (SCP-MF3WQS/SCP-MF3WEQS):

1. Pull the magnifier back towards you allowing the pins inside the hinge component to be unlocked as shown in Fig 5.
2. Rotate the magnifier clockwise till the hinge component is locked, so that your view through the dot sight is not obstructed as shown in Fig 6.



Fig 5.



Fig 6.

E. Adjusting Focus / Diopter Setting:

Note: Different individuals will have different eye focus which will result in different diopter setting. A person will use different diopter settings with or without eye glasses. The repeating process below may cause eye strain and contribute to parallax error. It will help if you can briefly look away from the eye piece and then look back through it.

1. Aiming your dot sight/magnifier at a distant target.

- Slightly rotate the focus ring until you have the sharpest image as shown in Fig 7.



Fig 7.

F. View Centering(SCP-MF3WEQS):

- Put your magnifier at the flip-over position.
- Without the magnifier, sight in the dot sight which is installed on your application together with the magnifier.
- Put your magnifier back at the vertical position.
- Look through the magnifier, if the dot is not in the center of the view, turn the adjustment lock screws counter-clockwise by a full turn, which should loosen the locks. Then, adjust the windage/elevation as shown in Fig 8. until the dot is in the center of the view. Tighten the adjustment lock screws again by turning them clockwise.

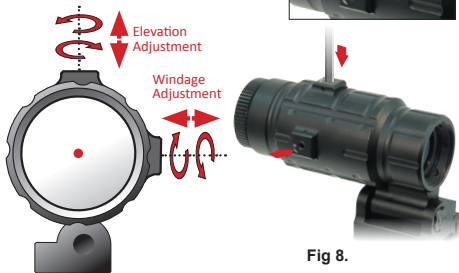

Fig 8.

G. Care and Maintenance:

1. Take care not to drop or knock the magnifying scope once it is zeroed.
2. Maintain the metal surface of the magnifying scope by removing any dirt or sand with a soft brush so as to avoid scratching the finish.
3. Wipe the lens with a clean flannel cloth to keep it clean and dry. In order to avoid scratching the glass, ensure both the lens and cloth are clean. Do not use finger or finger nail to touch/clean lenses.
4. Store the magnifying scope in a cool dry place when not in use. Be careful to avoid contact with acid, alkaline or corrosive chemicals.
5. Do not attempt to lubricate any part of the magnifying scope.
6. Do not disassemble the magnifying scope. Do not loosen or remove screws or parts. Any such or similar actions will void the warranty.

CAUTION: Viewing the sun can cause serious eye injury. Never look directly into the sun with this or any scope.

H. Lifetime Manufacturer's Warranty

Warranty against material or workmanship defects applies based on the following conditions -

- Magnifier scope was a first-hand purchase. Evidence of purchase is required for warranty service. Warranty is not transferrable.

- Magnifier scope was not disassembled, parts/ screws not removed or loosened, and the scope was not tampered with in any way. Any evidence of such interference will void the warranty.
- Magnifier scope has not been abused, maliciously damaged or treated in a manner not in keeping with the purpose it was designed for.

For Warranty service, please contact the scope distributor and provide a written problem description to obtain a Return Authorization Number before returning the product for repair or replacement.

Leapers, Inc., headquartered in Michigan, U.S.A., has been in the business of supplying shooting, hunting and outdoor gear since 1992. We set un-compromised high standards for all of our business operations. Our goal is to provide a total solution for any line of products we offer. We pay close attention to industry trends and customer feedback, with a focus on making the best-in-class niche products available for hunting, shooting and outdoor enthusiasts like you.

**EXPLORE
MORE
AT**

WWW.LEAPERS.COM



www.LEAPERS.com
32700 Capitol Street
Livonia, MI 48150 U.S.A.

Tel:(734)542-1500

Fax:(734)542-7095

Email:office@leapers.com